

WAKEFIELD EQUIPMENT

2024-2025 PRODUCT CATALOG

MACHINERY & EQUIPMENT FOR THE FENESTRATION INDUSTRY



Horizontal & Vertical Stretch Wrappers



Custom Window Dollies



Custom Glass Dollies

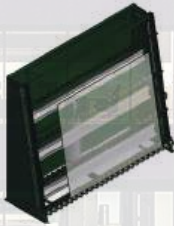

Glass Inspection Stations



Insulated Glass Dollies



Glass Cutting Tables



Free Fall Racks & Bases



Harp Racks



www.WakefieldEquipment.com
440-899-5658



Harp-Type IG Racks

TigerStop
fast and accurate...every time



Caster Tables



Pneumatic Tilt Transfer Tables



Mobile Air-Float Tables



Assembly & Squaring Racks

sales@wakefeldequipment.com

20140 Detroit Road • Cleveland, OH 44116 • PH: 440-899-5658 • FX: 440-899-5661

Specializing in...

Vertical & Horizontal Stretch Wrap Machines • Up-Cut, Chop & V-Notch Saws • Copy Routers & Gas Filling Machines
• Punch Presses & Cart Caddy • Custom Built Equipment • Window & Door Assembly Lines • Screen Tables • Lineal
Positioners & Saw Stops • Glass & Material Handling Equipment ...**And Much More!**

WINDOW ASSEMBLY
EQUIPMENT

9

TABLES &
CONVEYORS

17

GLASS & EXTRUSION
STORAGE

25

RACKS & DOLLIES

31

LINEAL
POSITIONERS

41

STRETCH WRAP
MACHINES

47

GAS FILLING
EQUIPMENT

51

SAWS & CUTTING

53

PROFILE
EQUIPMENT

61

TABLE OF CONTENTS

Introduction: 3-7

Window Assembly Equipment: 9-15

Pages 10-11

Glass Inspection Station, Window & Glass Manipulator, Spacer Printing Station, Desiccant Filler, Window & Door Transfer Systems, Oversized Door Assembly Rack with Pneumatic Tilt, Hydraulic Door Press

Pages 12-13

Window Assembly & Transfer Systems, Standard Assembly Rack, Casement Assembly Rack, Double-Sided Assembly Rack, Tilt & Horizontal Assembly, Pneumatic Tilt & Press Racks

Pages 14-15

Patio Door Assembly Racks, Vertical Transfer, Mechanical Panel Assembly, Rotation or Turning, Roller Presses, Drill & Staple Station, Free Fall Arm, Glass Washer

Tables and Conveyors: 17-24

Pages 18-19

Air Float Free Fall Tables, Traveling Table, Manual Cutting Tables, Overhead Spacer Conveyors, Freestanding Conveyor, Edge Deletion Tables

Pages 20-21

Caster Sealing Tables, Caster Transfer Tilt Tables, Grid Application Tables, Super Spacer & Swiggle Application Tables, Butterfly Table, Sunburst Table, Custom Power Conveyors

Pages 22-24

Tilt Work Tables, Flat Work Tables, Laser Etching Air Table, Seaming Table, Film Application Table, Carousel, Door Barrel, Automated Rotation Table, Manual Rotation Table, Pneumatic Tilt Table with Extendable Sides, Screen Table

Glass and Extrusion Storage: 25-29

Pages 26-27

Mobile Bases, Free Fall Stoce Racks, Lifting Bars, Pocket Type Extrusion Dollies, Extrusion Storage Dollies

Pages 28-29

Collapsible Shipping Racks, Floor Mounted Extrusion Racks, Glass Drawer Storage System, Extrusion Drawer Storage System

Racks and Dollies: 31-39

Pages 32-33

IG Dollies, Harp-Type IG Dollies, Heavy Duty IG Dollies, Harp Racks, Twin Level Harp Racks, Twin Level IG Dollies

Pages 34-35

Oven Racks, Slotted Glass Dolly, Glass Storage Racks, Spacer Racks, A-Type Shipping Rack

Pages 36-37

Window Dollies, Triangle Dollies, Frame and Sash Dollies, Dollies with Center Dividers, CartCaddy, Floor Dollies, Custom Door Dolly

Pages 38-39

Transport and Shipping Racks, Specialty Dollies, Shop Dollies, A & L Glass Dollies

Lineal Positioners: 41-45

TigerStop

Stretch Wrapping Machines: 47-50

Vertical & Horizontal Stretch Wrap Machines, Lineal Wrappers, Screen Stretch Wrappers

Gas Filling Equipment: 51

CompuGas Gas Filling Machine, TGE MultiGas Fillers

Saws & Cutting: 53-59

CTD Chop Saws, V-Notch Saws, Vertical V-Notch Saws and Double Miter Saws, Atech Upcut Saws

Profile Equipment: 61-62

Punch Press, Copy Routers, Automatic Single Corner Vinyl Welding Machine, End Milling Machines

WAKEFIELD EQUIPMENT

Working to Increase Your Productivity and Profits

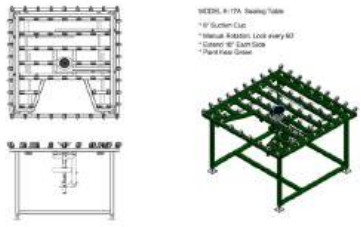

Model K-17A Beading Table
 *16" Section Cut
 *Variable Section Load every 60"
 *Custom "W" Beam Size
 *Hard Floor Cover

WAKEFIELD EQUIPMENT
 10770 Wilshire Court
 Channahon, IL 61615
 Phone: 815-499-3438
 Fax: 815-499-3443
 Web: www.wakefieldapp.com

Assembly and Window Transfer
 Assembly squaring racks and window transfer lines to improve your quality and product flow.



Model K-26B 12'
 * 2" Dia. x 8" Long Nuts at 12" Center
 * Hard Floor Cover

Approved _____
 Approved with Changes _____

WAKEFIELD EQUIPMENT
 10770 Wilshire Court
 Channahon, IL 61615
 Phone: 815-499-3438
 Fax: 815-499-3443
 Web: www.wakefieldapp.com

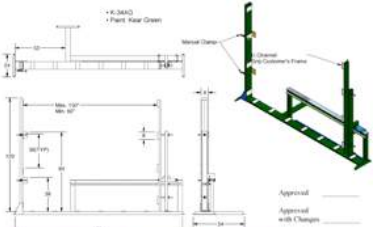

* K-3400
 * Fixed Four Doors

Approved _____
 Approved with Changes _____

WAKEFIELD EQUIPMENT
 10770 Wilshire Court
 Channahon, IL 61615
 Phone: 815-499-3438
 Fax: 815-499-3443
 Web: www.wakefieldapp.com

Glass and Material Handling
 Glass dollies and racks plus material handling products designed for your industry.



Approved _____
 Approved with Changes _____

Door Assembly Press
 *Hydraulic Cylinder Pressure Adjustable

WAKEFIELD EQUIPMENT
 10770 Wilshire Court
 Channahon, IL 61615
 Phone: 815-499-3438
 Fax: 815-499-3443
 Web: www.wakefieldapp.com

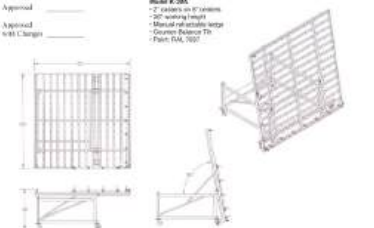

Approved _____
 Approved with Changes _____

Model K-28S
 *2 Casters and 8" Casters
 *50" Working Height
 *Standard Variable Leggs
 *Customizable Top
 *Paint: DMG, 302

WAKEFIELD EQUIPMENT
 10770 Wilshire Court
 Channahon, IL 61615
 Phone: 815-499-3438
 Fax: 815-499-3443
 Web: www.wakefieldapp.com

Saws and Lineal Positioners
 Chop, V-Notch and Double Miter saws plus lineal positioners to help your entire cutting operation.



K-60D Insulated Glass Dolly
 *40" Deep Ridges
 *60" Dia. - 1 in. Capacity
 *12" Frame Length
 *Low Profile Length 18"
 *Hard Floor Cover

Approved _____
 Approved with Changes _____

WAKEFIELD EQUIPMENT
 10770 Wilshire Court
 Channahon, IL 61615
 Phone: 815-499-3438
 Fax: 815-499-3443
 Web: www.wakefieldapp.com

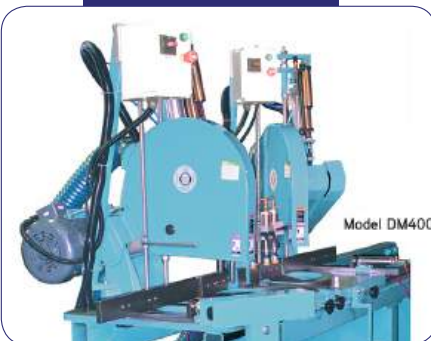

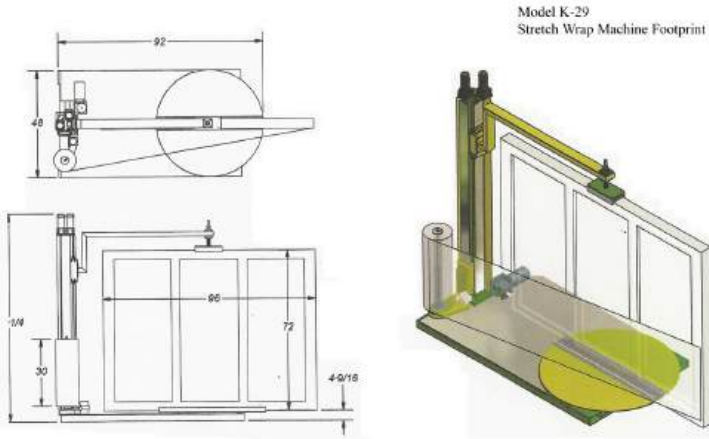

Model K-29
Stretch Wrap Machine Footprint

Stretch Wrapping and Screen Tables
Both vertical and horizontal wrappers to protect plus screen tables for improved quality.

WAKEFIELD EQUIPMENT

©2011 All Rights Reserved. Concepts contained herein are the intellectual property of Wakefield Equipment and may not be duplicated in any form without express written consent of Wakefield Equipment.

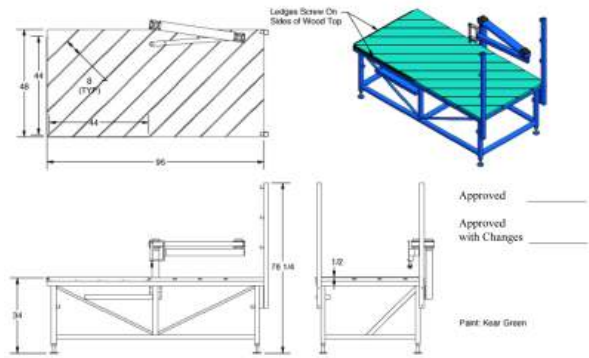

WAKEFIELD EQUIPMENT

©2011 All Rights Reserved. Concepts contained herein are the intellectual property of Wakefield Equipment and may not be duplicated in any form without express written consent of Wakefield Equipment.

30720 Jefferson Court
Cleveland, Ohio 44140
Phone: 440-399-3138
Fax: 440-499-5661
Web: www.wakefieldequip.com

OUR MISSION

Wakefield specializes in the fenestration industry searching out the best possible products on the market. We know that no single equipment manufacturer is the best at everything, and that's why a careful selection process is necessary. Each machine in our line is qualified using two major criteria- price and performance. In addition, we make sure that they are state of the art. So, if you're looking for the best, turn to the experts. **We're here to help.**

WAKEFIELD EQUIPMENT

WINDOW ASSEMBLY EQUIPMENT

K-34P

- Center squaring support extends out and squares from both sides
- Both center and side squaring member can move along entire frame
- Both squaring members have solid support to prevent bowing on side joints and middle frame
- Paint: Kair Green

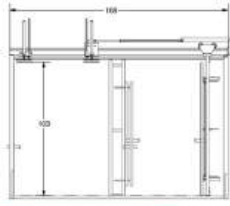

Approved _____
Approved with Changes _____

WAKEFIELD EQUIPMENT

20720 Jefferson Court
Cleveland, Ohio 44140
Phone: 440.899.5658
Fax: 440.899.5661
Website: www.wakefieldequipment.com

With today's labor market, no aspect of the manufacturing process should be left unstudied. The assembly process is often one of the more labor-intensive operations where small improvements can result in big rewards.

Wakefield offers several products to help fabricators in these areas. One of which is a line of window assembly and squaring racks that are affordable, versatile and custom-built to your specifications.

Door Assembly Press

- Hydraulic Cylinder Pressure Adjustable

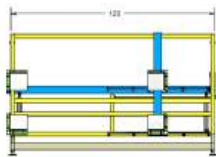

WAKEFIELD EQUIPMENT

20720 Jefferson Court
Cleveland, Ohio 44140
Phone: 440.899.5658
Fax: 440.899.5661
Website: www.wakefieldequipment.com

Serious Materials

- 4" x 4" x 12"
- Paint: Kair Green

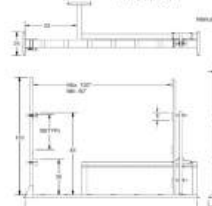

Approved _____
Approved with Changes _____

WAKEFIELD EQUIPMENT

20720 Jefferson Court
Cleveland, Ohio 44140
Phone: 440.899.5658
Fax: 440.899.5661
Website: www.wakefieldequipment.com

Model K-34P

- 1 Fixed & 1 Movable Vertical Press
- Press Down 12"
- Paint: Kair Green

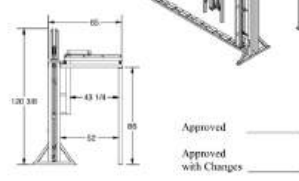
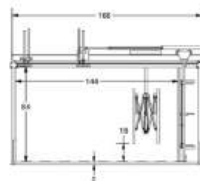

Approved _____
Approved with Changes _____

WAKEFIELD EQUIPMENT

20720 Jefferson Court
Cleveland, Ohio 44140
Phone: 440.899.5658
Fax: 440.899.5661
Website: www.wakefieldequipment.com

Model K-28A

- Pressure: 750 lbs
- Heavy duty slide left/right and center/middle to enable access to entire window assembly
- Paint: Kair Green

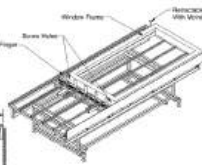

Approved _____
Approved with Changes _____

WAKEFIELD EQUIPMENT

20720 Jefferson Court
Cleveland, Ohio 44140
Phone: 440.899.5658
Fax: 440.899.5661
Website: www.wakefieldequipment.com

Model K-08B 10'

- 10' Tall x 10' Long Series 4000 Series
- Special Coating: 4000 High-Resist Material
- Paint: Kair Green



WAKEFIELD EQUIPMENT

WINDOW ASSEMBLY EQUIPMENT



Glass Inspection Station

- Eliminate rejected units
- Fluorescent lights makes it easy to spot scratches, bubbles, debris and other potential flaws
- Ledge rollers make for easy load/offload
- Built to your specifications



Window & Glass Manipulator

- Ideal solution that enables a single employee to handle the work of two
- Swiftly move glass units up & down, forward & reverse
- Will pick up and lay down horizontally
- Fabricated to handle up to 1,000 pounds
- Built and designed to your specifications



Spacer Printing Station

- Fits all sizes of aluminum spacers
- Variable speed (approximately 200 feet per minute)
- Load/Offload tables with stainless steel trays available



Desiccant Filler

- All steel construction
- Large capacity & air tight storage
- Free standing with adjustable height
- Saves material and labor

WINDOW ASSEMBLY EQUIPMENT

Window & Door Transfer Systems

Effective use of frame or sash transfer conveyers eliminate labor and provide an excellent work in process data. The vertical design typically has rollers. An allowance for nailing fins can be made. Horizontal conveyers can spin freely or be powered.

Hold down clamps can be added to create stability when needed. Transfer arms are available to merge sashes and frames into the same line for final assembly.

The tilt version can have a fixed ledge as shown which remains in place to minimize interference with the operator. This same feature can be incorporated into our pneumatic tilt assembly racks shown on the previous page.



Vertical Transfer

- Helps flow throughout shop
- Ledge smooth or rollers
- Ledge height varies for sashes or frames
- Available with hold down clamps or transfer arms

Tilt Transfer Tables

- Easily move window from vertical to horizontal
- Either pneumatic or counter-balance
- Back and ledge covered with HDPE or rollers
- Built to any size according to specifications

Horizontal Transfer

- For frames, sashes or completed units
- Top rollers have non-marking PVC
- Legs adjustable for height
- Built to any size or dimension



Oversized Door Assembly Rack with Pneumatic Tilt

Another example of how Wakefield Equipment helps the customer find solutions. This custom-built assembly rack makes the process of setting, clamping and moving oversized units to the next phase of your assembly process easier than you thought possible. Let us know how we can help you find the best solution for your plant.

Hydraulic Door Press

Ideal for pressing architectural and commercial doors, Wakefield's hydraulic door press offers 6,000 pounds of pressing force and is suitable for pressing header rails on to tempered glass doors. It features 3 suction cup-turning cylinders and its length is adjustable. Call us today to find out more about this impressive piece of equipment.



WAKEFIELD EQUIPMENT

Window Assembly and Transfer Systems

Increase productivity and quality with squaring racks, conveyors and transfer systems at an affordable price.

Model K-28B 8'

- 7" Dia x 8" Long Roller at 10" Center
- Paint: Kolor Green

Approved with Changes

WAKEFIELD EQUIPMENT

2028 Industries, LLC
 Cleveland, Ohio 44116
 Phone: 440.899.5628
 Fax: 440.899.5661
 Web: www.wakefield-equipment.com

Model K-28A

Modification Note:
 1. We will send three 2"x14" Upright Strips
 2. Customer: Glue Panel on the frame surface beside the rollers
 Make a slippery non-scratch support surface the same high as the rollers top.

Approved with Changes

WAKEFIELD EQUIPMENT

2028 Industries, LLC
 Cleveland, Ohio 44116
 Phone: 440.899.5628
 Fax: 440.899.5661
 Web: www.wakefield-equipment.com

Model K-20A

- 2" Center at 6" Center
- 2" Rollers High
- Manual Retrievable Bottom Ladder Roller at 10" Center
- Pneumatic Tilt 80°
- 2" Wheels, 2" Spaced, 2" Floor Lock
- Paint: Kolor Green

Approved with Changes

WAKEFIELD EQUIPMENT

2028 Industries, LLC
 Cleveland, Ohio 44116
 Phone: 440.899.5628
 Fax: 440.899.5661
 Web: www.wakefield-equipment.com

Model K-28A

- Pneumatic Tilt 80°
- Pneumatic Retrievable Ladder
- 5" x 1" Roller Array at 6" Center
- 1" Roll Solid HDPE on Top
- Adjustable Working High 35.0" - 47.0"
- Paint: S/M/T005 Pure White

Approved with Changes

WAKEFIELD EQUIPMENT

2028 Industries, LLC
 Cleveland, Ohio 44116
 Phone: 440.899.5628
 Fax: 440.899.5661
 Web: www.wakefield-equipment.com

K-34AG

- Paint: Kolor Green
- Mobile Champs at 45°, 24°, 60° and 80° High

Approved with Changes

WAKEFIELD EQUIPMENT

2028 Industries, LLC
 Cleveland, Ohio 44116
 Phone: 440.899.5628
 Fax: 440.899.5661
 Web: www.wakefield-equipment.com

K-35A

- 10 Rollers With Dots at 6" Spacing, 12" Center
- 2" Casters at 6" Spacing, 12" Apart
- Working High 26.0" - 31.0"
- Paint: Kolor Green

Approved with Changes

WAKEFIELD EQUIPMENT

2028 Industries, LLC
 Cleveland, Ohio 44116
 Phone: 440.899.5628
 Fax: 440.899.5661
 Web: www.wakefield-equipment.com

WINDOW ASSEMBLY EQUIPMENT

Vertical Assembly & Squaring

Assembly racks come in two basic designs: for hung windows with a 15 degree tilt and the open back design for casements or swing patio doors. The hung, or standard rack, also has a pneumatic lift (two feet of travel) option and can tilt (see below) to the horizontal.

Another option on the standard rack is retractable stops which recess for a continuous production flow. This is ideal when using a complete transfer system (see next page) for an un-interrupted and continuous production flow.

Standard Assembly Rack

- Holds and squares window during assembly
- Ergonomic design tilts back 15 degrees
- Has protective back and bottom strips
- Options include retractable sides and tilt



Casement Assembly Rack

- Open back for casements & swing doors
- Positioned 90 degrees from floor
- Vertical member applies pressure
- Available in different sizes and designs



Double-Sided Assembly Rack

Just one more innovation that we've added to our full line of squaring and glazing racks. With several options available, these racks can be custom made to suit any application. If you need retractable squaring members, pneumatic lift or a casement-type rack to access both sides of window, door or patio, we've got you covered.

- A-Frame design ideal for space limitations
- Use for squaring, glazing and any other application
- Have retractable members or pneumatic lift on either side
- Built for use on any size window or door



Tilt & Horizontal Assembly

Pneumatic tilt squaring racks can be mobile or stationary. These are basic variations on our standard assembly rack and have some of the same options such as retractable stops.

Also available are work tables for assembly from tilt to flat tables. These are economical ways to handle large units, and speed up production.



Pneumatic Tilt & Press Racks

- Ideal for large windows which need mulling
- Protective HDPE strips on back
- Rail moves as either vertical or horizontal
- Casters and floor lock optional

WINDOW ASSEMBLY EQUIPMENT

Patio Door Assembly Racks

The racks previously shown work extremely well for patio doors as well as windows. Shown here is another specialty rack which is similar to the casement rack previously shown but with the added feature of scissors to hold the fixed insert while the movable unit is put into the frame.



It uses both horizontal and vertical clamps to hold the frame in place. With the fixed member locked in with scissors, attaching the movable panel becomes simple and allows for testing.

Patio door assembly often requires that the fixed panel be positioned prior to placing the moveable panel into the frame.

Mechanical Panel Assembly



This rack is ideal for assembling large mechanical units such as patio door inserts or large non-operable units.

The glass is laid on the rotator in the horizontal position. The rotator lifts and turns for easy application of boot glazing and both the top and bottom

rails. The squaring members then apply pressure to ensure a tight fit. When the operation is complete, the finished product is tilted up to the vertical to be transferred down the line.

Mechanical units have screw together rails which are usually assembled directly over the glass, and require a specifically designed squaring rack.

Vertical Transfer

By adding rollers to the surface of a pneumatic tilt table, units can be taken off the vertical line and then transferred horizontally into a wrapper. In this operation, rollers would typically also be on the bottom ledge. Conversely, a unit coming out of a wrapper or a horizontal assembly line can be tilted down to easily slide into a window dolly for easy transport to the shipping area. As with all roller conveyers, the rollers are non-marking for use with vinyl, wood or aluminum. Oversized cylinders for heavy windows and closer roller spacing are a couple options to consider.



Transfer can be performed in any direction, or for any purpose.

Rotation or Turning

Quite often larger units will have to be turned. This is common with patio doors which require that the movable panel overlaps the fixed panel prior to wrapping. The rotator shown below is normally used when the product is transferred after assembly from a vertical conveyer and then placed into a vertical stretch wrap machine.



Rotators along with tilt tables enable one worker to perform the job normally required of two.

WINDOW ASSEMBLY EQUIPMENT



Roller Presses

- Minimizes breakage and provides accurate gap sizes for I.G. units
- Extra-wide capacity and custom work height
- Available with a heated roller press for insulated glass units
- Custom gap size available

Drill & Staple Station

- Drill holes directly in to your lineals to secure fixtures such as locks and handles.
- TigerStop length per specification (machines range from 4-30 feet)
- Adjustable drill and staple gun
- Up/down pneumatic clamps
- Programmed to store your unique work order



Free Fall Arm

- Eliminates the need for manually dropping or holding glass
- Can be mounted in several different positions around free-fall table
- Independently drops different glass types from free-fall bases or drawer system
- Use with your existing system or part of new glass line from Wakefield Equipment

Glass Washer

- Comes in 2 main sizes: 60" capacity and 84" capacity
- Standard features include circulating detergent & rinse systems, heater safety shut-off, stainless steel tank, dividers and pumps
- Up to ¼" thickness, no adjustment
- 5 pairs of solid rubber rollers throughout
- Clamshell top allows for easy access to service



TABLES AND CONVEYORS

Application tables come in a variety of shapes and sizes, and serve multiple purposes. Not only are they an important part of the assembly process, they are also an ideal way to keep things moving smoothly in your production line.

Wakefield offers numerous tables and conveyors that serve fabricators in many different areas of their production process. The following pages offer just a small sample of ways that we can maximize productivity in your plant.

K-35B

- 12 Rollers With-Dowel At 8" Spacing, 10" Center
- 14 Balls
- 4" Working High (38" H)
- Paint: Kear Green

3070 Jetstream Case
Cleveland, Ohio 44140
Phone: 440.899.5658
Fax: 440.899.5661
Wakeup@wakefield.com

WAKEFIELD EQUIPMENT

K-20

- 7" X 7" Cluster Table
- 2" Diameter X 7" Spacing on 8" Centers
- 38" Inspection Lights (8 total)
- 4 adjustable feet +/- 4"
- Paint: Kear Green

Approved
Approved with Changes

WAKEFIELD EQUIPMENT

12" Charcoal Conveyor

- 2 rows of 4" Balls @ 10" Spacing
- 4" Working High (38" H)
- 30" X 12" Table (38" H)
- Paint: Kear Green

Approved
Approved with Changes

3070 Jetstream Case
Cleveland, Ohio 44140
Phone: 440.899.5658
Fax: 440.899.5661
Wakeup@wakefield.com

WAKEFIELD EQUIPMENT

* Ball Roller At 8" Center, 5/8" Grid Formica Top

* 34" ± 2" Working High

* 6" Cup, Pneumatic Sliding and Rotate Brake

* Manually Tilting, Pneumatic Retractable Ledges

* Foot Pedal For Suction Cup

* Paint: Kear Green

Approved
Approved with Changes

3070 Jetstream Case
Cleveland, Ohio 44140
Phone: 440.899.5658
Fax: 440.899.5661
Wakeup@wakefield.com

K-31 Butterfly Table

- 12 Rows of 4" Balls @ 10" Spacing, 10" Center
- 4" Working High (38" H)
- 30" X 12" Table (38" H)
- Paint: Kear Green

Approved
Approved with Changes

3070 Jetstream Case
Cleveland, Ohio 44140
Phone: 440.899.5658
Fax: 440.899.5661
Wakeup@wakefield.com

WAKEFIELD EQUIPMENT

* Model K-28WT

* Paint: Kear Green

Approved
Approved with Changes

WAKEFIELD EQUIPMENT

WAKEFIELD EQUIPMENT

3070 Jetstream Case
Cleveland, Ohio 44140
Phone: 440.899.5658
Fax: 440.899.5661
Wakeup@wakefield.com

W35E1171K Working Table

- 14" Suction Cup
- Manual Rotation, Lock down 120°
- Retractable Ledges For 4" Balls @ 10" Center, 10" Center
- Paint: Kear Green

Approved
Approved with Changes

WAKEFIELD EQUIPMENT

K-410CT

- 14" Cup, Pneumatic Lock and Lock-Release 90°
- 14" Suction Cup
- 14" Suction Cup, 120°
- Retractable Ledges For 4" Balls @ 10" Center, 10" Center
- Paint: Kear Green

Approved
Approved with Changes

WAKEFIELD EQUIPMENT

3070 Jetstream Case
Cleveland, Ohio 44140
Phone: 440.899.5658
Fax: 440.899.5661
Wakeup@wakefield.com

TABLES AND CONVEYORS



Air Float Free Fall Tables

- Ideal for dropping, moving and cutting sheets of glass
- Top covered with heavy industrial carpet
- One horse power air float with 3 and 5 H.P. options
- Optional manual or pneumatic breaker bars



Traveling Table

- Efficiently transfer glass from several different racks
- Add air-float option for free-fall applications
- V-groove casters on existing tracks, or purchase with table
- Electric drive unit for smooth, easy travel



Manual Cutting Tables

- Glass drops for cutting on industrial carpeted top
- Can have counter-tilt or pneumatic tilting
- Optional air float and breaker bars
- Either stationary or mobile with floor lock



TABLES AND CONVEYORS



Overhead Spacer Conveyors

- Typically 8' to 20' feet long, but customization is available
- Hooks on 6" centers
- Travels 7' per minute
- Perfect for facilities with space constraints

Freestanding Conveyor

- Great for storing and moving spacers
- Moveable to different locations in your facility
- Perfect alternative to an overhead conveyor
- Can be built and modified to your specifications and applications



Edge Deletion Tables

- Adjustable grind for any thickness
- Non-marking caster top with work space
- Available with 1 or 2 edge deleters
- Available in any size or shape

TABLES AND CONVEYORS



Caster Sealing Tables

- A good way to seal edges of I.G.
- Center suction cup holds glass in place
- Non-Marking Swivel Casters on Top
- Built with various caster spacing
- Available with different platform surfaces, as a standalone or with extendable sides
- Standard Spacing of 6", 7" or 8"
- Adjustable height and various sizes



Caster Transfer Tilt Tables

- Used to tilt either single lites or I.G.
- Pneumatic or Counter Balance tilt
- Bottom ledge either solid or with rollers
- Top can be swivel casters or rollers
- Available as stationary or mobile with floor lock

TABLES AND CONVEYORS



Grid Application Tables

- Long wearing Formica top with grid pattern
- "L" Type, "A" Type or pneumatic tilt or lift
- Air float and air suction options
- Built to any size with caster & floor lock options

Super Spacer & Swiggle Application Tables

- Non marking Formica top with air float
- Six inch suction cup with lineal slide
- Electric rotation of cup
- Pneumatic retractable squaring sides



Butterfly Table

- The centerpiece of an efficient I.G. unit manufacturing process
- Custom built to customer specifications
- Short cycle time and fully automated operation
- Reduce waste and improve accuracy



Sunburst Table

- Non-marking top with grid alignment marks
- Create half-rounds and other sunburst patterns in your I.G.
- Eliminate wasted I.G. units
- Available in any size



Custom Power Conveyors

- Ideal for use in any tempering or cleaning operations
- Options available for XY transferring
- Available with donut rollers, belts, steel and PVC rollers
- Built to your specifications

TABLES AND CONVEYORS



Tilt & Horizontal Assembly: Tilt Work Tables

- For positioning large size windows
- Counter-balance or pneumatic tilt
- Optional casters and floor lock
- Built to any size

Flat Work Tables

- Keeps product stable
- Adjustable hold down pins
- Middle platform for storage
- Variety of sizes



Laser Etching Air Table

- Easily mount the laser of your choice
- Provides stable setting for laser etching identification or certification
- Special carpeted top won't scratch units
- Air-float makes it easy to move units on and off

Seaming Table

- Built to your specifications for mounting any type of seaming machine
- Ergonomically designed to increase efficiency and reduce fatigue
- Non-marking casters to handle heavy units without incident
- Perfect for multiple applications



Film Application Table

- Efficiently apply film outside of individual lites or I.G. units
- Automatic feed makes for a productive cycle
- Available for any width of glass and built to your specifications

Carousel

- Easily access various types of film without taking up valuable space
- Eliminates time consuming process of setting up individual film
- Can be set up to automatically rotate to the film type you select
- Built in any size



TABLES AND CONVEYORS



Door Barrel

- Allows for easy access to both sides of unit
- Can be operated by a single employee
- Eliminate back injuries due to heavy lifting
- Can be fabricated to use in multiple applications

Automated Rotation Table

- Save time and avoid injuries
- Solid HDPE strips over steel makes for easy transfer
- Pneumatically raise the center section and rotate 360°
- Great for multiple applications and built to order

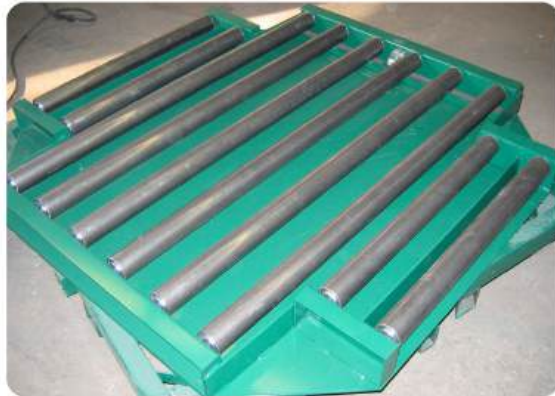

Manual Rotation Table

- Economical and user-friendly
- Roller surface makes for easy loading and unloading
- Add tabletop to an existing work table, or have one custom built for you

Pneumatic Tilt Table with Extendable Sides

- Retractable ledges make it easy to work while in horizontal position
- 3 side extensions to accommodate larger units for assembly
- Built to your dimensions and different tabletop surfaces are available



TABLES AND CONVEYORS

Screen Table - Making screens is an extremely labor intensive operation.

Usually, only a few select employees are able to perform the job, and there can still be quality problems and the potential of developing carpal tunnel syndrome.

If this concerns you, take a hard look at this system. Developed to offer an economical way to increase productivity, insure quality and eliminate carpal tunnel, it can be a critical piece of equipment to your operation.

Each **Wakefield** screen table comes with three film spool rods and three spline rods. The top is made from non-marking Formica which is grooved for self-locking discs. These discs provide exact squaring for each screen.

The spline insertion wheel is actuated pneumatically with the use of a trigger. This wheel glides across the table to any position, and is suspended with an articulating arm. The arm has two sets of ball bearings for effortless movement.

Each **Wakefield** screen table has a heavy duty welded steel frame. It is adjustable in height from 30 to 36 inches to accommodate all workers. It is best used with fiberglass mesh. These tables will:

- Increase your operation
- Reduce operator fatigue
- Give consistent quality
- Simplify your operation

Remember, when it comes to look at your production needs, turn to us. We're here to help with high performance, and affordable products.



GLASS AND EXTRUSION STORAGE

Another common problem encountered by manufacturers is storage space. Adding on, or moving to a larger facility isn't always an option and sometimes that extra space is simply a matter of bringing some order to your existing facility and getting creative with the existing space that you have.

Wakefield Equipment offers solutions that are ideal for today's manufacturers with a wide range of storage systems and racks that are an economical alternative to costly expansion.

Call us today and see how we can help design a system that's right for you and your budget.

Model K-30E
 1" x 2" Castor 1200Lbs Capacity, 4 Shelves
 7 Level Universal Bar (Optional)
 PAINT: RAL 5010

Approved _____
 Approved With Changes _____

WAKEFIELD EQUIPMENT
 27850 Rexford Avenue
 Cleveland, Ohio 44140
 Phone: 440.899.5658
 Fax: 440.899.5661
 Web: www.wakefieldequipment.com

Model K-32F
 15 Tiers
 96" H x 96" W x 130" D

Approved _____
 Approved With Changes _____

WAKEFIELD EQUIPMENT
 27850 Rexford Avenue
 Cleveland, Ohio 44140
 Phone: 440.899.5658
 Fax: 440.899.5661
 Web: www.wakefieldequipment.com

Model K-14 Standard
 Frame Full Depth
 7 Tiers
 72" H x 72" W x 130" D

Approved _____
 Approved With Changes _____

WAKEFIELD EQUIPMENT
 27850 Rexford Avenue
 Cleveland, Ohio 44140
 Phone: 440.899.5658
 Fax: 440.899.5661
 Web: www.wakefieldequipment.com

Model K-27
 40" X 2" Phenolic Casters (4 swivel)
 •Welded construction
 •5/8" steel arms
 •Additional vertical upright with arms
 •Custom Paint

Approved _____
 Approved With Changes _____

WAKEFIELD EQUIPMENT
 27850 Rexford Avenue
 Cleveland, Ohio 44140
 Phone: 440.899.5658
 Fax: 440.899.5661
 Web: www.wakefieldequipment.com

© 2010 All Rights Reserved. Concepts contained herein are the intellectual property of Wakefield Equipment and may not be duplicated in any form without express permission.

•14 Extrusion Drawers
 •15-Shelf Metal Drawers

WAKEFIELD EQUIPMENT
 27850 Rexford Avenue
 Cleveland, Ohio 44140
 Phone: 440.899.5658
 Fax: 440.899.5661
 Web: www.wakefieldequipment.com

Model K-24T
 2 1/2" Thick 1000LBS Load
 10" High
 10" x 10" Castor, 4 Right Hand
 10" Mesh Bottom

Approved _____
 Approved With Changes _____

WAKEFIELD EQUIPMENT
 27850 Rexford Avenue
 Cleveland, Ohio 44140
 Phone: 440.899.5658
 Fax: 440.899.5661
 Web: www.wakefieldequipment.com

Model K-24R
 12 x 10 Inches 40" H x 24" W
 7" High Mesh Bottom
 4" Castor, 4 Castor

Approved _____
 Approved With Changes _____

WAKEFIELD EQUIPMENT
 27850 Rexford Avenue
 Cleveland, Ohio 44140
 Phone: 440.899.5658
 Fax: 440.899.5661
 Web: www.wakefieldequipment.com

Walters & Wolf
 14 Extrusion Drawers
 15 Shelf Metal Drawers

Approved _____
 Approved With Changes _____

WAKEFIELD EQUIPMENT
 27850 Rexford Avenue
 Cleveland, Ohio 44140
 Phone: 440.899.5658
 Fax: 440.899.5661
 Web: www.wakefieldequipment.com

Model K-20
 12" x 10" Phenolic 40" H x 24" W
 7" High Mesh Bottom
 4" Castor, 4 Castor

Approved _____
 Approved With Changes _____

WAKEFIELD EQUIPMENT
 27850 Rexford Avenue
 Cleveland, Ohio 44140
 Phone: 440.899.5658
 Fax: 440.899.5661
 Web: www.wakefieldequipment.com

Open Fall Rack
 144" H x 120" W x 24" D
 1000LBS or 4000LBS Capacity
 2" Mesh Bottom, 10" Mesh Top, Safety Bar

Approved _____
 Approved With Changes _____

WAKEFIELD EQUIPMENT
 27850 Rexford Avenue
 Cleveland, Ohio 44140
 Phone: 440.899.5658
 Fax: 440.899.5661
 Web: www.wakefieldequipment.com

GLASS AND EXTRUSION STORAGE



Mobile Bases

- For dropping glass from steel returnables
- Weight capacity of 8,000 pounds
- Large phenolic wheels & floor lock
- Optional front safety bar and side shield



Free Fall Stocce Racks

- Hard rubber back makes it ideal for stocces
- Available in two-sided A, or one-sided L frame design
- Weight capacity of 8,000 or 16,000 pounds
- Can be either stationary or mobile



Lifting Bars

- Capacities of 4000 to 10000 pounds
- Handles stocces up to 17 feet
- Regular and low headroom designs
- Very competitively priced

GLASS AND EXTRUSION STORAGE



Pocket Type Extrusion Dollies

- Ideal for sorting random cut extrusions
- Vertical type for longer extrusions
- Horizontal type for small parts or sashes
- Typical pocket of sizes of 4, 5, 6 or 8 inches
- Tube-type or box-type designs available



Extrusion Storage Dollies

- Available in a variety of configurations
- Either A or L type designs
- Mobile with floor locks or stationary
- Capacities of 500 to 1500 pounds per shelf



GLASS AND EXTRUSION STORAGE



Collapsible Shipping Racks

- Racks are collapsible for stacking, shipping and storage
- Typical inside storage dimensions of 30 x 30
- Only 12 inches high when folded
- Additional designs including nesting units available



Floor Mounted Extrusion Racks

- Ideal for sorting and storing raw material
- Weight capacity of 1500 pounds per level
- Typical 16 ft. long & 18" arms
- Will build to specifications

Additional Rack Designs

Products such as nesting racks and custom designed storage systems are available.

Contact us for additional information.

GLASS AND EXTRUSION STORAGE



Glass Drawer Storage System

- Great for organizing and storing large size glass
- Available either floor mounted or table height
- Standard 10 drawer and larger models
- Will build to any size or customer specification



Extrusion Drawer System

- Great way to save space
- Easy access to any type lineal
- Draw dollies hold up to 6000 pounds
- Build to any width or depth



ADDITIONAL CONFIGURATIONS

Besides the products shown, we can build you a drawer storage system according to your specifications. For additional information, contact us.

RACKS AND DOLLIES



Standard I.G. Dollies

- Economical means to store random I. G.
- Easy I. G. loading with wood or PVC flip-up fingers
- Made from all steel construction
- Bottom protective strips on base and pull handle



Harp Type I.G. Dolly

- Diagonal harp type PVC covered divider rods
- Additional vertical rods used to stabilize glass
- Base & back covered with protective strips
- Has sides for shipping



Heavy Duty I.G. Dolly

- Steel swing-up fingers with PVC covering
- Grooved HDPE bottom strips for extra support
- All welded steel construction
- Standard floor lock and pull handle

RACKS AND DOLLIES



Full Base Harp Racks

- Ideal for separating and transporting single lites
- Full 100% HDPE grooved base ideal for easy loading
- Divider rods covered with protective PVC
- Available with different slot widths and sizes
- Also available with partial base



Twin Level Harp Racks

- Great way to save space
- Used for single lites or I.G.
- Standard with floor lock
- Available in different sizes

Twin Level I.G. Dolly

- Two rows of diagonal rods
- Perfect for storing large and small units
- Full and partial bases available
- Built to your specifications



RACKS AND DOLLIES

Oven Racks are available in a number of different designs with different slot widths and sizes. They are heat tolerant for tempered and I.G. units. You can choose from partial bases, to full bases of slotted HDPE. The divider rods are non-marking and twin level racks are available for smaller units. Also, floor locks or locking casters are available. For your shipping needs, forklift stirrups & reinforced construction are offered.



RACKS AND DOLLIES



Slotted Glass Dolly

- Push/Pull handle makes for easy maneuvering
- Slotted HDPE base and backing
- Hold-down swing away bar keeps units secure
- Built to your specifications



Glass Storage Racks

- Ideal for storage of large quantities of glass
- Available in two-sided A, or one-sided L design
- Typical size ranges from 4 to 6 feet deep
- Optional hard rubber on rails to protect glass



Spacer Racks

- For moving assembled spacers
- Swivel casters
- Steel construction
- Bottom fingers rotate down to allow for longer top spacers



A-Type Shipping Rack

- Ideal for shipping and storing
- Bottom fork lift tongues for lifting rack
- Rubber protective sides and wood ledges standard
- Available in any size

RACKS AND DOLLIES

Once the product is transported to the proper work stations, assembled and tested when needed, the final stage is moving the finished product. These dollies have been designed to do the job.

You can choose between our economical completed window dolly (as shown below), or one of the other options which provide more random access to your product.

As always, if you have difficulty deciding on the right product, contact us. We've helped thousands of fabricators make the right decision. Let us help you.



Completed Window Dollies

- Most economical design for complete units
- Used for both window transport and storage
- Welded frame with wooden base and sides
- Will build to any length or specification



Triangle Dollies

- Allows easy access of finished goods
- Bottom MDF dividers separate product
- May be used in the shop or for shipping
- Built to customer specifications



Frame and Sash Dollies

- Makes window transport an ease
- Both one and two sided designs
- Protective divider rods and wide slots
- Available in any size



ADDITIONAL CONFIGURATIONS

Besides the products shown, we can build you a complete assembly system according to your specifications. For additional information, contact us.

RACKS AND DOLLIES



Dollies with Center Dividers

- Keeps product from sliding over
- Ideal for high units such as doors
- Post type dolly also used for I.G.
- Available in any size



CartCaddy

- Use one person to move what would usually take 2
- Custom attachments to fit all racks and dollies
- Increases productivity
- Can help eliminate back injuries and workers' compensation claims



Floor Dollies

- Simple way to move large single units
- Slotted or rubber base depending upon use
- Available for windows or glass
- Built to customer specifications



Custom Door Dolly

- Front end roller makes for easy loading
- Slotted HDPE base and support fingers keep units securely in place
- Perfect for transporting around the facility or shipping
- Built to your specifications

RACKS AND DOLLIES



Transport and Shipping Racks

- A wide variety of options available
- Shipping rack (on left) has removable sides and stacks
- Patio door rack (below) has fork lift tongues on both sides
- Will build to customer print and requirements



Specialty Dollies

- Window and door carts (far right)
- Furniture glass dollies (below left)
- Jobsite dollies (below center)
- Tillet dollies (below right)



RACKS AND DOLLIES

If You Think All Racks and Dollies Are the Same...



...then it's time to call Wakefield Equipment.



Shop Dollies

- To transport various sizes of cut glass
- Weight capacities of 3000 or 5000 pounds
- Available with either wood or rubber sides
- Phenolic wheels and pull-handle standard



A & L Glass Dollies

- Ideal for moving glass cases or stoves
- Available in two-side A, or one side L design
- Either wood or protective rubber sides
- Capacities of either 4000 or 8000 pounds



LINEAL POSITIONERS

With a tight labor market, one of the fastest payback machines which **Wakefield** offers is the **TigerStop** lineal positioner. **TigerStop** is:

- Productive with increases of well over 100% as opposed to manual stops.
- Simple to use. Most operators can be trained in less than 5 minutes.
- Accurate, with repeatability of 4 thousandths of an inch.
- Fast, with speeds in excess of 3 feet per second.
- Expandable using communications and optimization software.
- Versatile for applications from window frames to I.G. spacers.
- Affordable, with prices starting around \$5000.

TigerStop is normally sold as a positioner with a working length of 10 feet, but is also available in sizes from 4 feet up to 30 feet. The longer **Tigers** can be used for curtain wall, or as a pusher. However, the most economical length is 10 feet, and 95% of our sales are in this range.

Some of the more popular options are extended stops, attachment hardware, and tables. Call us, and we'll discuss the model and options which best suit your needs.

If optimization is important, there are various programs available. Many of these optimization packages are included with those popular manufacturing software programs used in our industry, and they interface with **Tiger**. Call us for a list of suppliers.

For the small investment it requires, **TigerStop** has surprised many fabricators with its fast payback and ease of use. We encourage you to take a hard look at this machine.



LINEAL POSITIONERS

Why Buy a Positioner?

There are a multitude of reasons to place an automatic lineal positioner in your facility. Most studies show a production increase of three fold over manual stops. The greater the number of different lengths that are cut over a production cycle, the faster the payback. A few of the many benefits that a lineal positioner will provide include:

- Reduced labor in changing set ups.
- Increased measurement accuracy.
- Use of less skilled labor in cutting.
- Overall faster production rate.

Another major benefit of a positioner is the ability to interface cut lists, and reduce material cost through optimization. This application is discussed in more detail in the pages that follow.

Perhaps the fastest, and most cost effective means to reduce labor today is with lineal positioners strategically placed throughout the shop.

Why Tiger?

Today, fabricators spend substantial sums of their capital budgets to acquire costly, and often, complicated equipment. Without a doubt, many of these expenditures are justified. Quite often, however, a simple item such as a lineal positioner, placed **throughout the factory**, can offer a quick, and guaranteed payback. This is one of the strengths of *TigerStop*.

Due to *Tiger's* cost, it can be placed in a multitude of areas to perform a variety of chores. Besides conventional uses for positioners such as frame and sash lineals, *Tiger* can be justified in areas never before considered. Some of the uses beside frame and sash measuring includes screen rail, glazing beads, I.G. spacers and more.

Traditionally, positioner use has been restricted due to price. A machine which costs in excess of \$10,000 has limited applications. Since *Tiger* sells for a fraction of the price of other positioners, a multitude of new uses can now be considered.

The uniqueness of Tiger is tied directly to its low cost which enables it to be used in a much wider variety of applications.

What about Reliability and Performance?

Today, there are thousands of *Tigers* in operation. Many of these have been in continuous use for years. There is no other lineal positioner on the market with a track record like *Tiger*.

When it comes to performance, the statistics are equally impressive. *Tiger* is:

- Accurate with repeatability of 4 thousandths of an inch.
- Fast with speeds in excess of 3 feet per second.
- Easy to use with typically operator training time of under 5 minutes.

Each machine comes with an easy to read operating manual with complete instructions for simple set up and immediate use. *Tiger* operates on 100 volt, single phase electric and is ambidextrous, or non-handed so it can be set up on either side of the machine or saw you'll be using.

Support is available through both **Wakefield** and *Precision Automation* with replacement parts shipped with same day service.

Tigers will operate equally well in a wood, vinyl, fiberglass or aluminum environment.

As with all equipment using a microprocessor, clean power is needed, and a line filter with a surge protector is highly recommended. Please consult with your local electrician when first setting up *Tiger*.

Tiger has one of the finest track records of any machine in its category.

Tiger is easy to set up, simple to use, and a cinch to maintain.



LINEAL POSITIONERS

Which Model & What Accessories Do You Recommend for my Tiger?

TigerStop is available in various lengths from 6 to 30 feet. The most is the 10 foot version since it is the most price effective, and works well for most applications. Remember, that the length of the machine refers to the working dimension (the actual extrusion is two feet longer) which means that a 10 foot machine, for example, can cut anything within a ten foot range (1 to 11 feet, 2 to 12 feet etc. depending upon where it is set next to the saw).

The most popular way to buy a *Tiger* is as a basic unit which includes a stand to mount the controller and line filter. Since most fabricators are replacing a manual stop, they usually already have a table. If a table is required, this option is also available. The most popular table is a smooth slide unit, however, there are roller tables for longer, heavier extrusions. A ledge stand can also be used, but only if the finished parts are immediately removed after cutting.

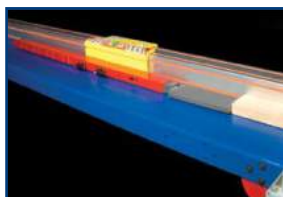

The last item to consider is the stop itself. *Tiger* comes standard with a flip away stop which comes to within 4-1/2 inches of the end of the extrusion. To this, one has to add the distance to the saw blade. If you cut pieces smaller than this, you might want to consider a "pusher foot" to move the stop closer to the blade. If you're cutting multiple pieces, a gang stop might be considered.

Besides these accessories, there are other options available to help increase your productivity. We'll be glad to review them with you. Give us a call, and we'll make sure that you get the right *Tiger*, with the right options at the right price.

The length of a Tiger refers to the overall range of movement.

The accessories you choose depends upon your particular needs, and we will help you with that selection.

What Software Should I Use?

Many *Tigers* are used as "stand alone" machines without an interface. In fact, most machines are initially sold this way, and communications are added later. Remember, if you plan to drive your *Tiger* through a PC, you must transfer the cut list into an

optimization package first. **Some programs currently working with Tiger include:**

- Caliburn
- Creative Systems
- D-Calc
- Fenevision
- Friedman
- G.D.S.
- Opti-Cut
- PainLess Window
- PMC Software
- Winsys
- Window Maker
- Window Magic
- WTS Paradigm

In most cases, an interface only requires Level Two Software. The exceptions to this are G.D.S., Friedman and Window Maker where Level Three may be required.

If you have a manufacturing program other than one listed above, and would like to optimize, contact us. Many of the above suppliers will be glad to work with you with just their optimization package.

Typically, optimization can save anywhere from 10 to 20% on material usage. The payback can become quite phenomenal, and in some cases will be only a few weeks. Besides material, there are substantial labor savings since cuts will no longer be entered manually. Contact us for more information.

You can purchase a Tiger as a stand alone unit at first, and add communications later.

Optimization software can save up to 20% on material costs which can sometimes reduce your payback to only a few weeks.

Conclusion

If you're like most manufacturers today, you want to stretch your investment dollar as far as possible. You know the importance of reducing labor, but have a multitude of priorities.

We firmly believe that *TigerStop* lineal positioners offer the absolute best possible payback for your investment. **Wakefield** has successfully put in scores of these installations throughout the United States and Canada with great results.

If you need additional information including a free video, please call. We want to help you on the path to higher productivity and reduced costs.

For more information, give us a call. We're here to help.

WAKEFIELD EQUIPMENT

TigerStop™

Lineal Positioners for the Fenestration Industry

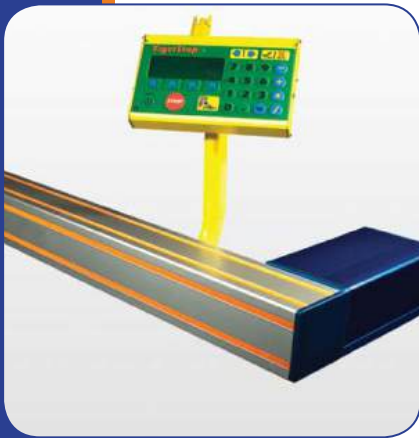

Get Fast, Get Accurate, Get Automated.



- You want faster production- to save time and money.
- You want every employee to easily make consistent, accurate measurements.
- You want versatile equipment that works your way.
- You want TigerStop. Get automated and get rid of your tape measurer!

Get automated, get productive.

It's simple: the more productive you are, the more successful you are. And today, automation is essential to productivity. Investing in **TigerStop** pays off immediately by increasing your productivity with automated measurements that are fast, accurate and consistent- so you produce more, with less waste.

Get versatile, get efficient.

Your shop should work your way: with **TigerStop**, it will. **TigerStop** automates almost any tool and setup- including table, miter, panel, and chop saws; boring and punching machines; and drill presses- and makes your production line faster by eliminating time wasted on manual processes. You can enter dimensions the way you want: in feet, inches, fractions or decimals, standard or metric. **TigerStop** also has a fully functioning calculator that adds, subtracts, multiplies and divides. By customizing **TigerStop** to your equipment, you'll be more efficient instantly.

TigerTalk (TigerStop)

"Accuracy is the key thing, and reduced operational errors. The TigerStop was dependable, reliable, and lived up to my production needs and capabilities. In fact, it improved production. I would buy another one."

– **Joe Mccord, Acme Window Products, Willowbrook IL**

"I'm using TigerStops on two double-miter saws, and on chop saws in the screen department, glazing department, and vinyl finishing department. TS is very small compared to other machines, it is user friendly and is far superior."

– **Craig Bachman, Champion Window Coverings, Denver CO**



TigerStop Specifications

Working lengths: 4' to 30'

(Custom length available at no upcharge. Overall length is 2' longer than working length.)

Power requirements: 110v @ 15 amps

Motor type: DC servo with optical encoder

Speed: Adjustable 10" ~ 35"/sec

Repeatability: +/- 0.004" (4/1000")

Number of cut lists/patterns: 99

Quantity per size: 999

Max number of sizes/positions: 2000

Measurement system: Inches & metric

Standard Features

- Set point stop mode
- Push feed mode
- Pattern mode
- Increment push
- 99 programmable hot keys
- 99 programmable cut lists

Upgrade options

- Standard interlock for semi-automatic operation
- Advanced interlock for fully automatic operation
- RS232 port for TigerSet communication
- Bar code reader
- TigerOptimizer & TigerLink for data download & optimization
- Label printing



STRETCH WRAPPING MACHINES

Protecting windows for shipment is a technology that has grown dramatically over the years. Wrapping windows, however, is a very unique process. Wrapping boxes on a pallet is entirely different than wrapping windows for shipment.

Wakefield is aware of the challenges associated with window wrapping, and for this reason, we offer reliable and economical stretch wrappers from manufacturers who know this particular market.

Vertical Stretch Wrappers:

The advantage of a vertical stretch wrapper is the ability to wrap practically any size window, and only one employee is required to operate the machine. Capacity per shift ranges from 275 to 300 windows and their affordability make them a must-have for any window fabricator.

Horizontal Stretch Wrappers:

Horizontal machines, sometimes referred to as ringers, have a unique feeding system designed just for windows and capacity per shift using two employees ranges up to 1000 windows. They are available as stand-alone units that can be integrated with existing feed conveyors, or can be purchased with in-feed and out-feed conveyors customized to your specifications.

Machines for Lineals & Screens:

These machines are specialty units. The lineal wrapper is patterned after horizontal models, while the screen wrapper functions more like the vertical models. Both have platens specifically designed for the application.

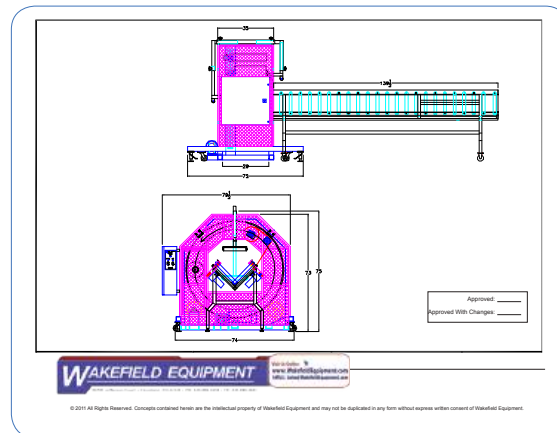
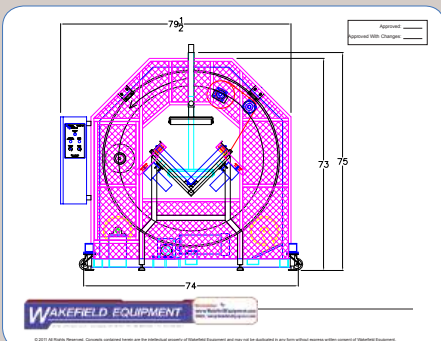
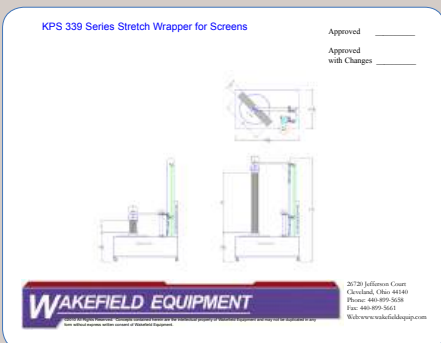
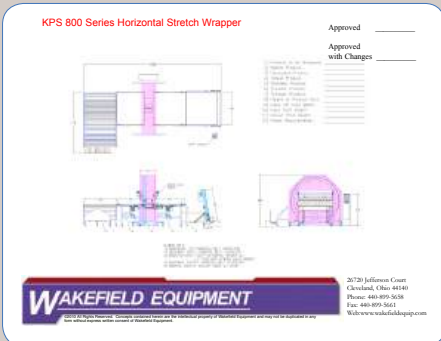
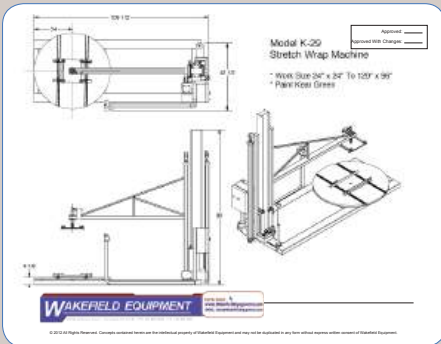

STRETCH WRAP MACHINES

Vertical Window Wrappers

Today, stretch wrap film is the preferred method of wrapping windows. And, the vertical stretch wrap design is the number one preferred method of wrapping random sizes.

Wakefield Equipment's stretch wrappers are designed for windows, and are not just another redesigned, or converted pallet wrapper. The continuous cycling with these constant demands requires a reliable window wrapper in your plant.

So, if packaging random size windows is a problem, we have your answer. Our line of vertical stretch wrap machines offer:

- Increased Productivity with a high speed design.
- More flexibility to wrap a wide variety of sizes.
- Reliability with 20 years of experience.
- Easy operation with a low profile table and swing out control panel.

Remember, Wakefield Equipment offers the only models of stretch wrap equipment that build machines exclusively to wrap windows. Tell us your requirements, and we'll give you a solution.



MAXIMUM WINDOW/PANEL HEIGHT 96"
MAXIMUM WINDOW/PANEL WIDTH 60"

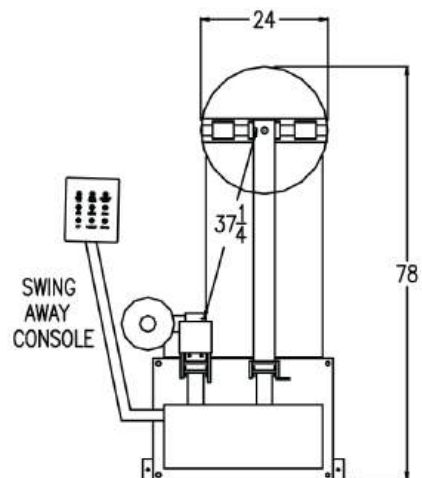
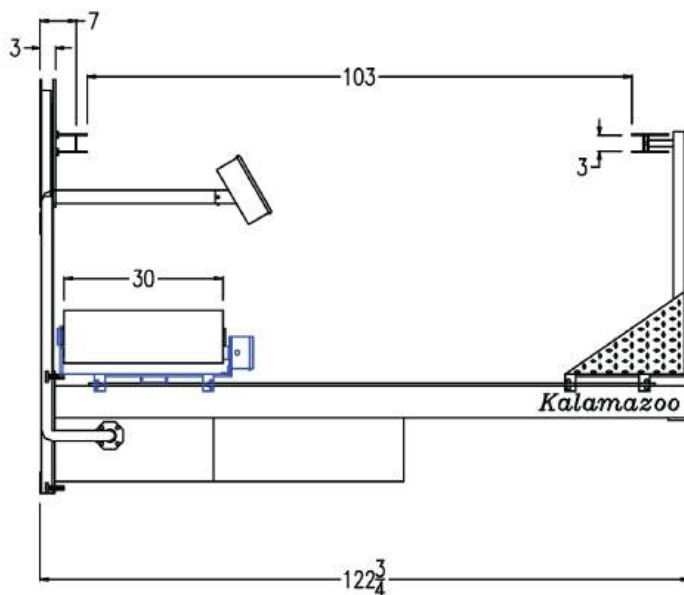

STRETCH WRAP MACHINES

Horizontal Window Wrappers

Horizontal wrappers, sometimes known as “ringers”, come in a variety of sizes. Typically, a 60 or 72 inch ring is used. Input and output conveyers are common, although, some ringer operations use a direct feed of the window into the ring without pre-staging it on a conveyer.



The horizontal stretch wrappers from Wakefield Equipment are unique for several reasons. This design was developed through years of experience in wrapping windows, and includes:

- Bottom rollers have a special polyurethane cover which helps “grab” the window for an easy feed.
- Top “donuts” ride over grooves and ridges in profile and keep windows straight during the wrapping process.
- Special Pro Gaff tape on donuts made with cloth help the window to track a straight line.
- Distance between rollers and donuts is easily adjustable to accommodate any size window.

The actual means to feed the machine is up to the customer. Two workers are normally required. Sometimes, infeed tables for staging are used. They can be either a slide type, or rollers. Contact us for suggestions on your applications.

Horizontal machines can wrap from 500 to 1000 windows per shift depending upon size. Test details are available.

If you would like to see a video of these tests visit “Video Gallery” at www.WakefieldEquipment.com. We’ll also be glad to send you a detailed proposal, and answer your questions. We’re here to help.

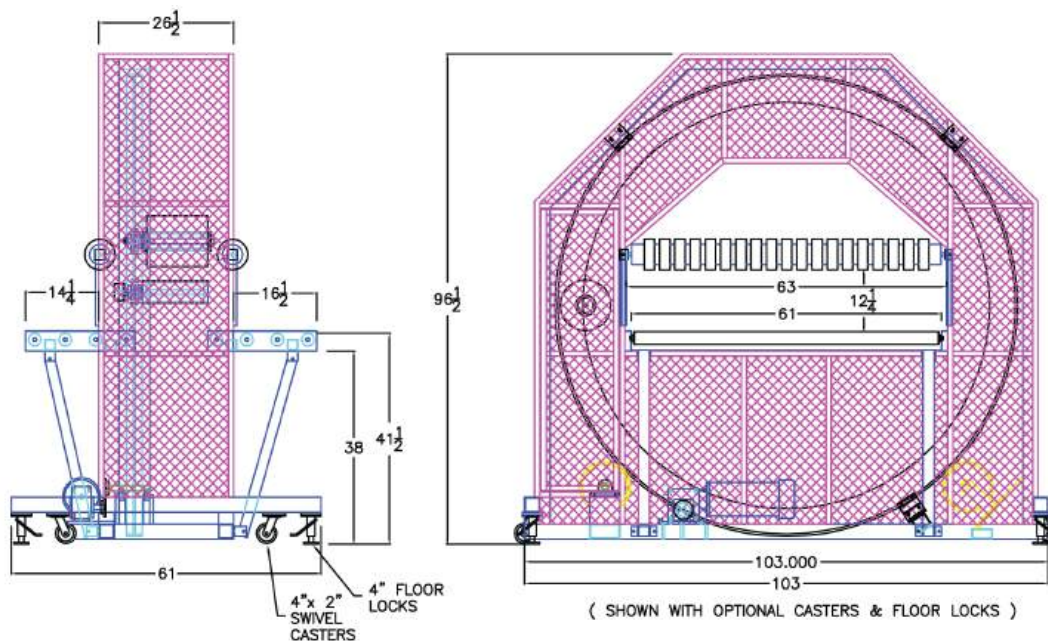

STRETCH WRAP MACHINES

Stretch Wrap Equipment for Lineals

Wrapping lineals properly is critical to avoid shipping damage and present the right product to your customer. As specialists in the fenestration market, we know the type of equipment that is required. This horizontal wrapper, or "ringer" is designed to do the job quickly and cost effectively.

Suggested film is 12" wide by 80 gauge fed with a rotating ring. The specialized rollers may be either steel or have a specialized polyurethane cover to minimize scratches and maintain appearance. The ring diameter in this photo is 30 inches and will take 22 inch bundles. Other sizes are available.

The adjustable top guide is removable, and may be either a "V" as shown or straight. The infeed table is usually manual feed while the outfeed can be manual or powered which allows one operator to handle the entire process.

For more details, including a video or a quotation for a machine to fit your application, give us a call. We've been helping fabricators for years with their wrapping needs.



Stretch Wrap Equipment for Screens

Wrapping screens is a specialty operation which requires knowledge and experience within the fenestration industry. As specialists, we have developed a machine for this purpose which is not only cost effective, but ideally suited for the application.

We have found that the best way to wrap screens is to bundle them first. This makes an ideal size package for handling and shipping to your customer. Note that the wrapper is on rollers to easily move as your needs change, and it is powered by 110 volt to make set up simple.

Each bundle is then placed on the bottom platen which has been specifically designed for screens. The top platen, which is also designed specifically for screens, is then lowered and the variable speed drive takes over.

It is spring loaded with a cut-off switch to prevent damage, and was developed after extensive research into the application and industry.

For more details on this screen wrapper including a video and proposal, give us a call. We've been helping fabricators for years with their wrapping needs, and we are available to help you.



GAS FILLING EQUIPMENT

The **CompuGas Gas Filling Machines** from **Wakefield Equipment** come with a steel rack for holding the gas machine and tank. Large caster wheels for easy movement and one timer per four hoses are also included. They are available as 2, 4, 8 or 16 stations and for use with Argon or Krypton.

Options:

- Proportionate Gas Mixing Capability
- One timer per hose
- Heat Mirror Application (Super Glass)
- Custom built machines to suit your specific needs

Gas Filling Dollies are also available.

TGE MultiGas Fillers

There are six models in our range, all of which work using the Filler/Sensor system to ensure that the sealed units are filled to 100%. Visual and audio indicators tell the operator when the sealed unit is full, the gas bottle is empty and how much gas is flowing in to the sealed unit.

The range of the machines comprise of the new basic Multi-1, which can be used with all gases, but is especially designed for use with Krypton, Zenon and SF6, with a gas flow rate of 10 to 12 liters per minute.

The new NM range has a gas fill rate of over 30 liters per minute and is ideal for filling Argon gas. The new combination machine, NM/Multi models have been designed and built to fill all gases at the correct filling speeds.

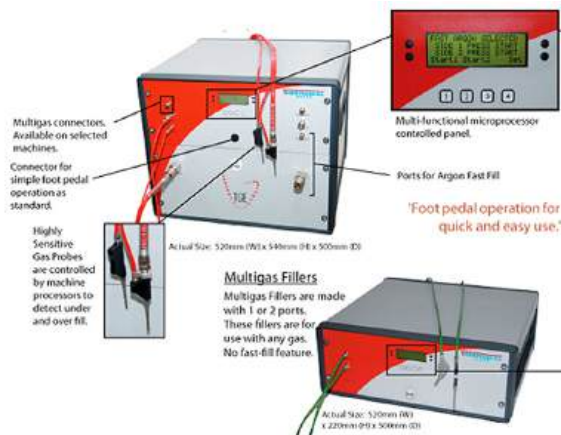

SAWS AND CUTTING

Wakefield offers several types of saws. Some of our more popular models include:

CTD Chop Saws

For a pneumatic feed of the head chop saw, we recommend CTD. Available with both miter cut and fixed head, these saws have a variety of options for practically any need.

CTD “V” Notch Saws

The model D45AX comes with either a 10, 12 or 14 inch cutting capacity. The pneumatic feed of the head is extremely fast since the operator does not have to wait for a full cycle before progressing to the next cut.

CTD Vertical “V” Notch Saws

CTD also offers the N80 and N90 models which are a “true vertical” and may be better suited for higher, and narrower profiles. We will be glad to discuss your requirements, and recommend the saw best suited for your application.

CTD Double Miter Saws

For precise cuts, and special applications, a double miter saw may be preferred. Priced higher than a “V” notch saw, it is not normally possible to put a lineal positioner on these saws.

Atech Up-Cut Saws

The Crater-02A and Crater-06A heavy-duty automatic up-cut saws make cutting large extrusions safe, easy and accurate. These saws can be used with a TigerStop to automate any cutting operation.

Measuring Devices

Although CTD and Atech both offer tables and gauges, lineal positioners are recommended for all your cutting equipment. With the **TigerStop** lineal positioner, it is now extremely affordable to maximize productivity by eliminating potential errors and the tremendous amount of time associated with conventional stops. For more information on **TigerStop**, refer to our section on “Lineal Positioners”.

SAWS AND CUTTING

12, 14, 16 & 20 Inch Diameter Blades

CTD 200 Series

- Either straight or miter cut with 12 or 14 inch blades
- Standard 2 HP with larger horse power options available
- Optional pneumatic feed of head
- Horizontal or vertical clamps

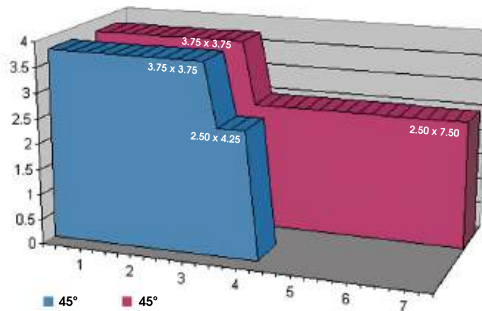

Cut chart shown for 12" saw. Please call for 14" chart.



CTD 400 Series

- Either straight or miter cut with 16 or 20 inch blades
- Standard 7.5 HP motor with magnetic starter
- Optional pneumatic or hydraulic feed of head
- Horizontal or vertical clamps

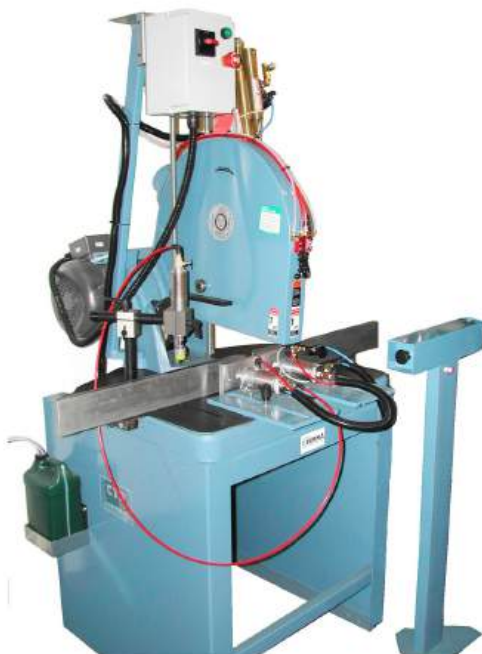

Cut Charts

Top for 45°, bottom for 90°, 16" blade in blue, 20" blade in red.

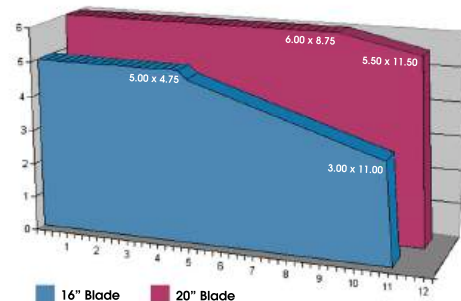
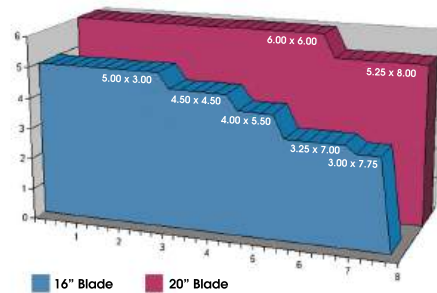

SAWS AND CUTTING

Double Miter Saws

- Available as 12" (Model DM200R) or 16" and 20" (Model DM400)
- Each head is moveable and will miter up to 45°
- Pneumatic feed of head and inside vertical clamps included
- Standard 8 foot bed



Additional Options

- Longer bed
- Digital read out
- Extra heads
- Additional pneumatic clamps
- Compound heads (see below for more information)

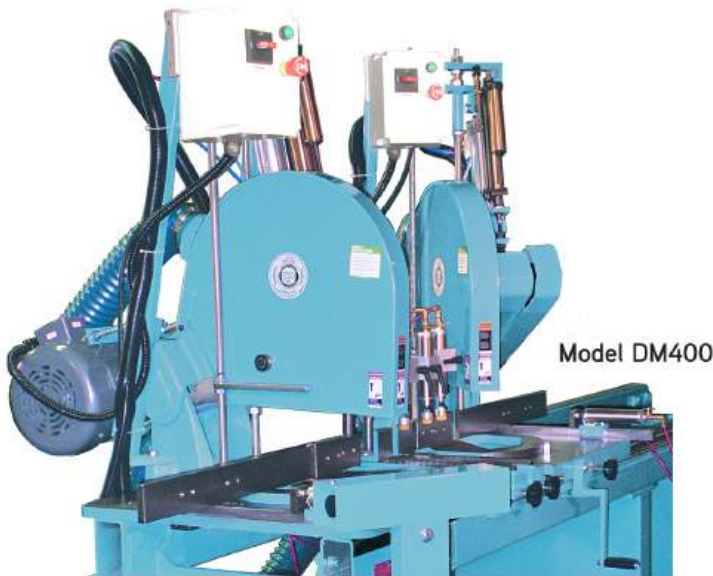

Compound Saws

- Available as a single-head (shown) or with double miter saws, as shown above
- Blade sizes of either 12" or 16"
- Pneumatic clamps available

**Cutting charts are available on all of these saws.
Contact us for the details.**



SAWS AND CUTTING

CTD D45AX Series

- Extremely fast cycle with up to a stroke per second
- Available with either 12" or 14" blades
- Standard pneumatic feed of head and adjustable fences
- Horizontal or vertical clamps

Cut chart shown for 12 or 14 inch blades

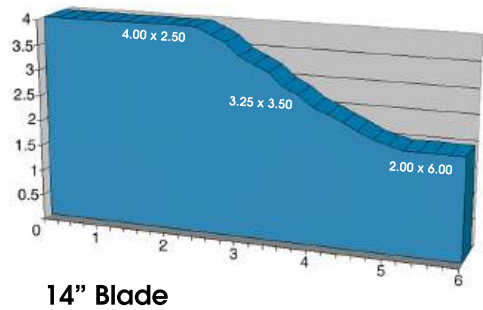
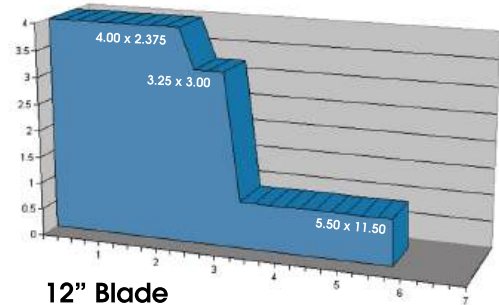
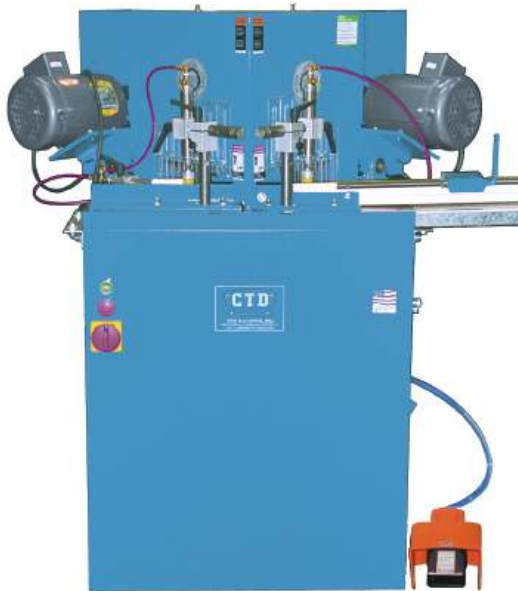

TRUE VERTICAL SAWS

CTD N80 & N90 Series

- Either 13" or 16" blades
- Ideal for high profiles
- Standard pneumatic feed with true vertical travel
- Horizontal or vertical clamps

Cutting Capacity

- N80: Up to 5" high
- N90: Up to 6" high



SAWS AND CUTTING**CTD Model M25RHC & F255RHC 14" Capacity Cut-Off Saws**

Have you ever considered something larger than your 12" chop saw, but couldn't justify the cost of a 16" machine?

Now, we have an answer. The new 14" chop saw from CTD.

Like no other saw on the market and best of all, it's "budget-friendly" with a price around what you would pay for a 12" saw.



The model M25RHC is a rugged, accurate, and heavy duty industrial cut-off saw which will miter up to 60°, with positive stops at 45°, 30°, 22.5°, 15°, 0°. The F255RHC cuts 90° only. Both the M25RHC and F255RHC are equipped with a 14" blade capacity, with 1" arbor. Both models come standard with 2 HP single or 3 HP three phase TEFC motor with a manual starter switch and two belt drive. Base and discs are made from precision machined iron castings for lasting accuracy. Fences are set on the centerline; however, they can be adjusted front to back for more width cutting capacity.

The Model M25RHC comes standard with our new air bearing system that allows easy movement of the head to various degrees with less than 5 lbs. of pressure.

The picture shows the machine with accessorized stand, conveyor and lube system, and air power feed. Please contact Wakefield Equipment for pricing & information on this and other optional equipment.

SAWS AND CUTTING

Crater-02A Heavy duty automatic upcut saw 16.5" (420 mm)

Standard Equipment

- 420 mm (16.5") carbide tipped saw blade
- Pneumatic twin horizontal & vertical clamps
- Air gun
- User's manual

Optional Equipment

- Infeed & outfeed tables
- Pneumatic spray mist lubrication

Specific Capacities

- Heavy duty construction for long machine life
- The moveable back fence enables you to cut bigger profiles both straight and miter cut
- When the cutting process is finished, the saw blade moves down to its starting point automatically for safety reasons
- Fixed angle adjustments at 15°, 22.5°, 30°, 45° and 90°. Intermediate angles are adjusted via mechanical stop

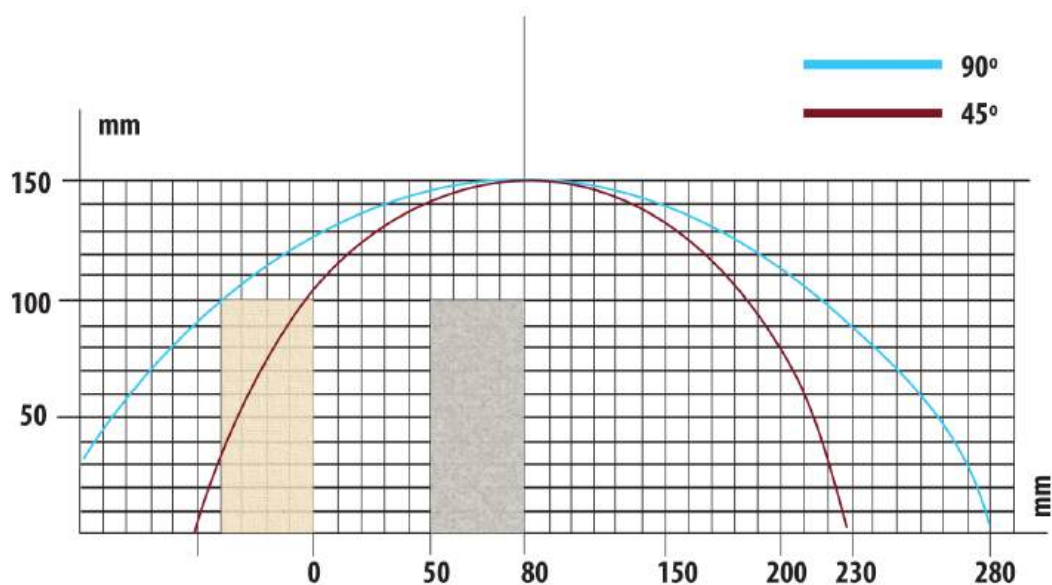

— 90°
— 45°

SAWS AND CUTTING

Crater-06A Heavy duty automatic upcut miter saw 18" (460 mm)

Standard Equipment

- 460 mm (18") carbide tipped saw blade
- Pneumatic twin horizontal & vertical clamps
- Air gun
- User's manual

Optional Equipment

- Infeed & outfeed tables
- Pneumatic spray mist lubrication
- Pneumatically operated upper guard



Specific Capacities

- Heavy duty construction for long machine life
- The moveable back fence enables you to cut bigger profiles both straight and miter cut
- When the cutting process is finished, the saw blade moves down to its starting point automatically for safety reasons
- Fixed angle adjustments at 15°, 22.5°, 30°, 45°, 90° and 60° on the right side. Intermediate angles are adjusted via mechanical stop
- The rising speed of the saw blade can be adjusted as required
- Built-in handle for turning the table to the desired cutting angle
- Net height cut 180 mm (7")

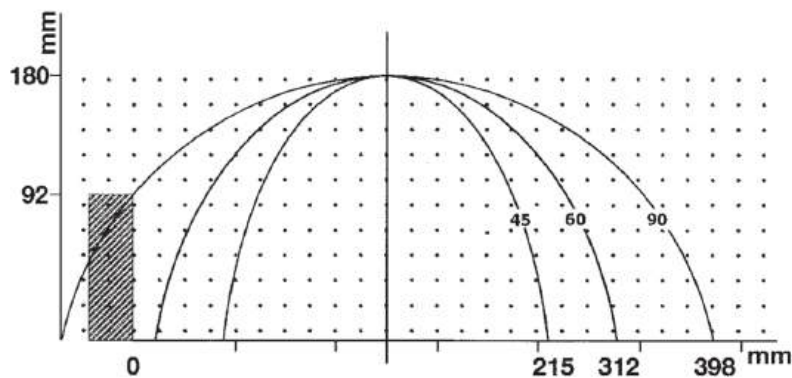

PROFILE EQUIPMENT

Every component that goes in to fabricating a window or door plays a crucial role in the quality of that completed product, and profiles are no exception.

Wakefield Equipment offers a full line of quality and economical equipment for vinyl and aluminum profiles that ensure precision and accuracy every time.

- Punch Presses
- Automatic Single Corner Vinyl Welding Machines
- Copy Routers
- End Milling Machines

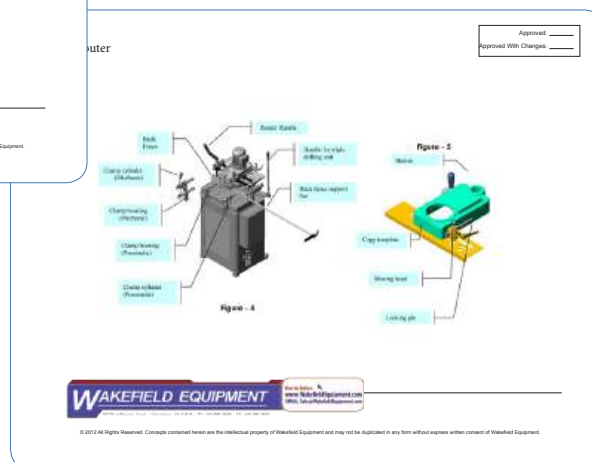
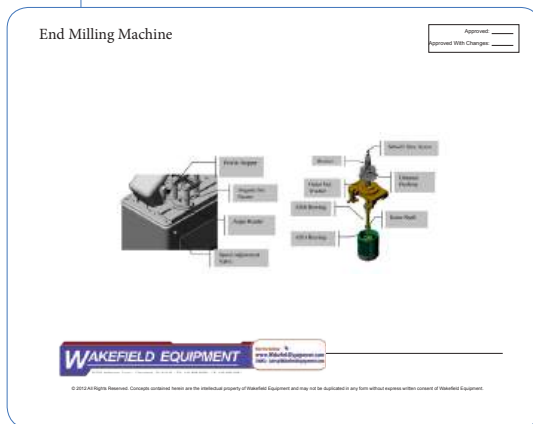
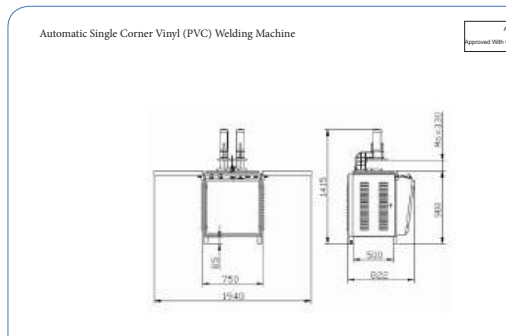

PROFILE EQUIPMENT

Punch Press

- Pneumatically punch holes or slots on to aluminum and vinyl (PVC) profiles
- 4 dies can be attached to the press simultaneously
- Changing dies is fast and easy
- Operates via pneumatic system with foot pedal
- Can be used with a profile support system



Copy Routers

- Designed to open key holes, slots, holes and other window & door accessory shapes on to PVC and aluminum profiles
- Available with manual or pneumatic clamps
- Copy templates are customized to profile drawings supplied by customer



Automatic Single Corner Vinyl (PVC) Welding Machine

- Composed of steel plate chassis for guaranteed stability
- Adjustable set squares placed over aluminum tables provides welding between 15° to 180°
- Equipped with electrical, pneumatics protection and safety systems for machine operator's safety
- Machine has been designed for corner connection of PVC profiles in 15° - 180° degrees by melting

For additional specifications and options on this machine give us a call today!



